



...PORTA-GANTRY®

500-3000



ASSEMBLY VIDEO

Assembly & Operation

www.reidlifting.com



PORTA-GANTRY® 500-3000

No. 1 in lightweight, portable, safe lifting solutions

CONTENTS

INTRODUCTION

CORRECT OPERATION

- Intended Use
- Inspection Prior to Initial Operation
- Inspection Before Starting Work
- Maximum Capacity

NOTES FOR CORRECT USAGE

- Warning
- Attaching the Load
- Temperature Range
- Regulations

INSPECTION/MAINTENANCE

- Regular Inspections
- Maintenance/Repair
- Storage and Transportation
- Marking

ATEX

- ATEX - Classification
- ATEX - Identification
- ATEX - Spark Formation
- ATEX - Static Electricity
- ATEX - Inspection, Maintenance & Repair

IRATA

LANGUAGE

ASSEMBLY INSTRUCTIONS

VARIANTS AND OPTIONS

- Wind Up Jack Legs
- WUJL Inspection / Maintenance
- Ratchet Beam Elevation System
- Easy Conversion to Winched Configuration
- Customised Configurations

PORTA-GANTRY RANGE

- Detailed Dimensions
- PORTA-GANTRY 5000
- PORTA-GANTRY RAPIDE

QUALITY & SAFETY

- Accreditations

TESTING

PRODUCT IPR

INSPECTION RECORD

INTRODUCTION

All users must read these operating instructions carefully prior to the initial operation. These instructions are intended to acquaint the user with the machine/hoist and enable him/her to use it to the full extent of its intended capabilities.

The operating instructions contain important information on how to handle the gantry in a safe, correct and economic way. Acting in accordance with these instructions helps to avoid dangers, reduce repair costs and down time and to increase the reliability and lifetime of the gantry.

Anyone involved in doing any of the following work with the gantry must read the operation instructions and act accordingly:

- Operation, including preparation, troubleshooting during operation and cleaning
- Maintenance, inspection, repair
- Transport

Apart from the operating guide, health & safety and accident prevention act valid for the respective country and area where the gantry frame is used, the commonly accepted regulations for safe and professional work must be adhered to.

It is incumbent on the user or instigator of work with the equipment that all users have suitable medical and physical capabilities. Likewise the competent person should ensure there is a rescue plan in place in the event of an emergency that could occur during the work.

N.B. This document should form an element of the overriding Risk Assessment and Method Statement required for each lift.

PORTA-GANTRY® 500-3000

No. 1 in lightweight, portable, safe lifting solutions

CORRECT OPERATION

Intended Use

The PORTA-GANTRY is intended to be used for the lifting of goods or the lifting of persons, or for providing a safety anchor for the prevention of falls.

N.B. We recommend that the device is dedicated to either goods or personnel use and where reasonably practicable to avoid using the structure for both.

PORTA-GANTRYs are suitable for Rope Access and have been tested to 15kN static load as per test requirements of IRATA International Code of Practice (ICOP).

Inspection Prior to Initial Operation

Each PORTA-GANTRY must be inspected prior to initial operation by a competent person. The inspection is visual and functional and shall establish that the structure is safe and has not been damaged by incorrect assembly, transport or storage. Inspections are instigated by the user.

Inspection Before Starting Work

The inspection procedure requires that a valid inspection/test certificate has been submitted to and checked by the user.

Before starting work inspect the gantry assembly and all load-bearing components for visual defects. Check the integrity of all profiles for denting and bolt holes for wear and elongation. Furthermore, test the trolley for free movement along the beam.

Ensure that the overall working load limit (WLL) is adhered to – following the necessary Risk Assessment and Method Statement.

Maximum Capacity

The PORTA-GANTRY is designed to lift and lower loads up to its rated capacity. The capacity indicated on the frame is the maximum working load limit (WLL) or safe working load (SWL) which must not be exceeded (definition is country dependent).

When being used as a personnel lifting anchor the user must use a body harness and retractable device or shock absorber to EN355, ANSI Z359.6-09 or CSA Z259.16-04 that limits the maximum allowed force (M.A.F.) to 6kN. Winches used with the PORTA-GANTRY should comply to EN1496:2017 or equivalent.

Only ONE person/load may be attached to ONE trolley in accordance with the WLLs.

The gantry has an up-rated capacity for personnel positioning. This is when the structure is to be used as an anchor for lifting persons that have a suitably low chance of falling through a free distance and only carried out following a comprehensive risk assessment.

While the PORTA-GANTRY has the capacities stated in the table below, it is only one part of a fall arrest system which is only as strong as its lowest rated component. Each lift must be properly planned and all weights clearly known along with the WLLs and constraints of all fall arrest system devices.

The PORTA-GANTRY has different ratings depending upon the application as detailed in the table below:

Application	Capacity			
Goods [kg]	500	1000	2000	3000
Fall Arrest*	3 persons	3 persons	5 persons	5 persons
Max. Combined Personnel Lifting Capacity [kg]	250	400	750	1000

*Only Applicable to PORTA-GANTRY systems being used in accordance with PD CEN/TS 16415:2013. When being used in accordance with EN795:2012, the structure shall be limited to a maximum of one user in fall arrest.

The capabilities stated in the table below are only applicable to standard range *PORTA-GANTRY* systems. Bespoke versions of the gantry are available tailored to specific lifting needs. If unsure about your system consult serial labels, information filled in on page 23 or consult your supplier. A custom gantry is designated by a product number ending with a "C" found on the serial label attached to each A-frame and the beam. For custom designed gantries please contact your supplier for appropriate rating and capabilities.

In the event of simultaneous goods and personnel combined lifting or when being used as a fall arrest system in sub-zero AND wet conditions contact the supplier as capacities may be reduced.

NOTES FOR CORRECT USAGE

- We recommend the use of load-sensing or overload protection devices on all lifts
- The Risk Assessment and Method Statement must consider additional loading resulting from any "wet lift" situations
- Ensure suitable winches and connection plates are used for all applications
- Due care and attention should be practiced when transporting and storing the gantry to avoid damage
- Assemble only as instructed (ensure all bolts are present and fitted correctly as per instructions).
- We recommend that gloves should be worn when using this equipment
- Set up the gantry at a safe distance from the hazard and subsequently move the structure into place
- The beam must be horizontal prior to any lift and A-frames vertical and parallel to each other
- Do not use the gantry if the trolley does not run freely along the beam
- Attach hoist only to the lifting point on the trolley
- Avoid side pull. Lowering and lifting should only be carried out when the load chain/lifeline form a straight and vertical line between the load and lifting attachment point on the trolley
- Do not allow load to swing
- When lifting keep the load low to the ground.

- **NEVER** walk away from structure whilst connected to the equipment i.e. connected by a fall arrest block or winch
- Only raise and lower loads when **CASTOR BRAKES** are **ENGAGED**
- When using the gantry as a fall arrest anchor the required clearance of the fall arrest device should be considered - refer to device's Assembly & Operation manual and consider the height adjustment on the gantry
- Before the gantry is used consideration must be given to the potential effects of the lifelines over sharp edges, chemical reagents, electrical conductivity, cutting, abrasion, climatic exposure and the effect of offset forces as a result of pendulum falls
- The gantry is not to be moved under load except when a Competent Person or authority approves a Risk Assessment and a Method Statement for a particular reason
- To ensure stability of the structure, the operating span of the beam must be equal to or greater than the distance between the castors on the A-Frame

Warning

- The equipment shall not be used outside its limitations, or for any purpose other than that for which it is intended
- When winching only one lifeline should be used with each sheave and they should never cross paths with each other
- Do not lift or transport loads while personnel are in the danger zone
- Do not allow personnel to pass under a suspended load
- When gantry is used with multiple persons attached working procedures should dictate that individual lifelines do not cross and become tangled
- It is **NOT** recommended to mix the use of the gantry with personnel and goods lifting concurrently
- **Never** leave a suspended load unattended
- Start moving the load along the beam only after it has been attached correctly and all personnel are clear of the danger zone
- Be aware of hazards when setting up/folding down, eg. hands/fingers trapped in rotating parts

No. 1 in lightweight, portable, safe lifting solutions

- It is essential for safety that the PORTA-GANTRY is withdrawn from use immediately should:
 - Any doubt arise about its condition for safe use
Or
 - It has been used to arrest a fall and not be used again until confirmed in writing by a competent person that it is acceptable to do so
- Be aware of adverse weather; high, gusty or moderate/strong breeze conditions could impose horizontal loads, potentially affecting the stability of the structure. If weather conditions are impacting lifting operations, work should be stopped and gantry should be disassembled. If disassembling is not possible, the gantry should be tied to a rigid structure to avoid overturn

Attaching the Load

The operator must ensure that the hoist is attached in a manner that does not expose him or other personnel to danger by the hoist, chain(s) or the load.

Temperature Range

The PORTA-GANTRY can be operated in ambient dry temperatures between -20° and +55°C (-4°F to 131°F). Consult your supplier in case of extreme working conditions. **If used in sub-zero and wet conditions, fall arrest appliances characteristics may change.**

Regulations

The PORTA-GANTRY complies with the following regulations:

ATEX Directive - 2014/34/EU, PPE Regulation (EU) 2016/425, Machinery Directive 2006/42/EC, The Provision and Use of Work Equipment Regulations 1998 (S.I. 1998 No. 2306), The Lifting Operations and Lifting Equipment Regulations 1998 (S.I. 1998 No. 2307). In conformity with AS/NZS 5532:2013. The safety regulations of the respective country for using manual lifting equipment must be strictly adhered to. EN795:2012, PD CEN/TS 16415:2013, ANSI Z359.18 and CSAZ259.16-15.

INSPECTION/MAINTENANCE

Regular Inspections

To ensure that the gantry frame remains in safe working order it must be subjected to thorough periodic inspections by a competent person. Inspections are to be 6 monthly for personnel lifting and 12 monthly for goods only unless adverse working conditions or profile of use dictate shorter periods. The components of the gantry frame are to be inspected for damage, wear, corrosion or other irregularities. To check for worn parts it may be necessary to disassemble the gantry frame. Particular attention should be paid to the areas of the structure described under Inspection Prior to Initial Operation.

Repairs should only be carried out by an approved specialist workshop that uses original spare parts. It is recommended that once inspected the device is marked with the date of next inspection.

Inspections are instigated by the user. If detailed information is required on inspection and test criteria, please refer to your supplier's technical department.

Please refer to page 23 for the equipment Inspection Record.

If using the Gantry in explosive atmospheres see additional section titled ATEX.

Maintenance/Repair

In order to ensure correct operation not only the operations instructions, but also the conditions for inspection and maintenance must be complied with. If defects are found **stop** using the PORTA-GANTRY immediately.

No alterations or additions to the equipment should be made without the written consent of the manufacturer. Any repair shall only be carried out in accordance with the manufacturer's procedures.

It is recommended to maintain the equipment in a clean and dry manner. Cleaning is suggested using a sponge or cloth with warm, soapy water (using diluted domestic washing up liquid), rinsing and allowing to dry.

Storage and Transportation

When transporting the components the user must take note of the manual handling considerations.

Do not throw the gantry or its components down or stack items on top of it. Always place properly on the ground avoiding damage to the equipment.

Marking

The serial labels indicate:

- The product identification number
- The product's unique serial number
- The goods' WLL of the device
- The year of manufacture
- The standards to which the device is approved
- The ATEX rating of the product (if applicable) - see ATEX section.
- CE 0088: Notified body number (currently LRQA) who are responsible for approving REID Lifting's quality control system



Read
Assembly & Operation instructions



PORTA-GANTRY 500-3000kg
Assembly & Operation instructions

ATEX

This product has been designed for use in explosive atmospheres. If the product is to be used in explosive atmospheres then the following section must be followed. Any different or exceeding use is considered incorrect and REID Lifting Ltd will not accept any responsibility for damages resulting from false application. The risk is solely with the user. If the product has been customised in any way then it may not comply with standards and not be suitable for use in explosive atmospheres. If this is the case then the product will not have any of the below marking. If in doubt contact your REID representative.

ATEX - Classification

As standard, the product meets the requirements of Category 3 equipment for use in Zone 2 explosive atmospheres, providing a normal level of protection where mixtures of air and gases, vapours or mists or by air/dusts mixtures are unlikely to occur or, if they do occur, are likely to do so only infrequently and for a short period only.

Or

The product can be supplied to meet the requirements of Category 2 equipment for use in Zone 1 explosive atmospheres, providing a high level of protection where mixtures of air and gases, vapours or mists or by air/dusts mixtures are likely to occur.

ATEX - Identification

In addition to the previous Marking section, the product will have the following identification on the serial label:

As Standard for Zone 2 Environments:

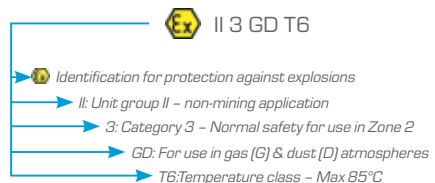

Or

As an Upgrade for use in Zone 1 Environments:

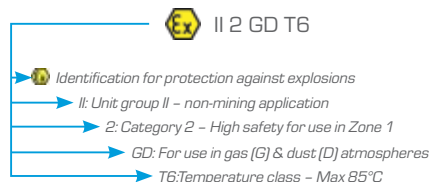

PORTA-GANTRY® 500-3000

No. 1 in lightweight, portable, safe lifting solutions

ATEX - Spark Formation

Increased danger of ignition may emanate from clashing of special material pairings. These are non corrosion-resistant steel or cast iron against aluminium, magnesium or pertinent alloys. This applies especially in case of rust or surface rust. When assembling the product and inserting fastening components they must be clear of rust and debris of any kind. Care must be taken to ensure the product is handled in a suitable manner, is never thrown and always placed onto the ground.

For Zone 1 and 2 applications, the height of the PORTA-GANTRY should **NOT** be adjusted using the ratchet mechanism and/or geared wheel within the said zone.

REID recommend the use of corrosion resistant tools when assembling the PORTA-GANTRY system to prevent the possibility of any sparks.

For ATEX Zone 1 use, stainless steel castor brackets are fitted to reduce the possibility of a spark.

ATEX - Static Electricity

For Zone 2 applications static electricity has been identified as potential for build up leading to an incendive spark. Although the risk of such ignition is unlikely the gantry must be earthed during assembly and use. This can be achieved by attaching a 4mm earthing lead to a convenient location on metallic parts of both the Gantry and Trolley.

In Zone 1 applications, for added explosion protection, the gantry is fitted with anti-static trolley rollers, stainless steel fasteners and therefore does not need to be earthed. However, the effectiveness of the conductivity during operation can be affected by a dirty tread or other environmental influences and therefore must be checked by the operator periodically.

ATEX - Inspection, Maintenance & Repair

If using the gantry in explosive atmospheres, in addition to the Regular Inspection/Maintenance information found on page 6, these additional instructions should be followed.

Inspections shall be instigated by the user prior to

each use if used in a potentially explosive atmosphere. Inspections and maintenance shall be carried out at a safe distance away from an explosive atmosphere.

Special attention should be given to dust deposits on the structure, especially in areas where the profiles come into contact, and should be wiped clean and care taken not to apply materials that could create electrostatic charging. Additionally the bearings in the trolley rollers and castors should be checked to ensure they rotate freely.

The structure is predominantly constructed from aluminium which will not rust. However there are steel components used throughout. These are the fasteners, castors, master-link, trolley rollers, A-frame height adjustment gearing system (if fitted) and the height adjustment ratchet (if fitted). Where there is sign of any rust deposits on the aluminium structure it should be wiped clean as above and where there is sign of rust on a steel component then that component should be removed from use and the structure not used until a replacement is fitted.

IRATA



PORTA-GANTRYs are suitable for Rope Access and have been tested to 15KN static load as per test requirements of IRATA International Code of Practice (ICOP).

LANGUAGE

It is essential for the safety of the user that if this product is re-sold outside the original country of destination the reseller shall provide instructions for use, maintenance, for periodic examination and for repair in the language of the country in which the product is to be used.

ASSEMBLY INSTRUCTIONS

N.B. Appropriate PPE should be worn:



Gloves



Protective footwear



Hard hat

The *PORTA-GANTRY* and its constituent components are described in the image below.

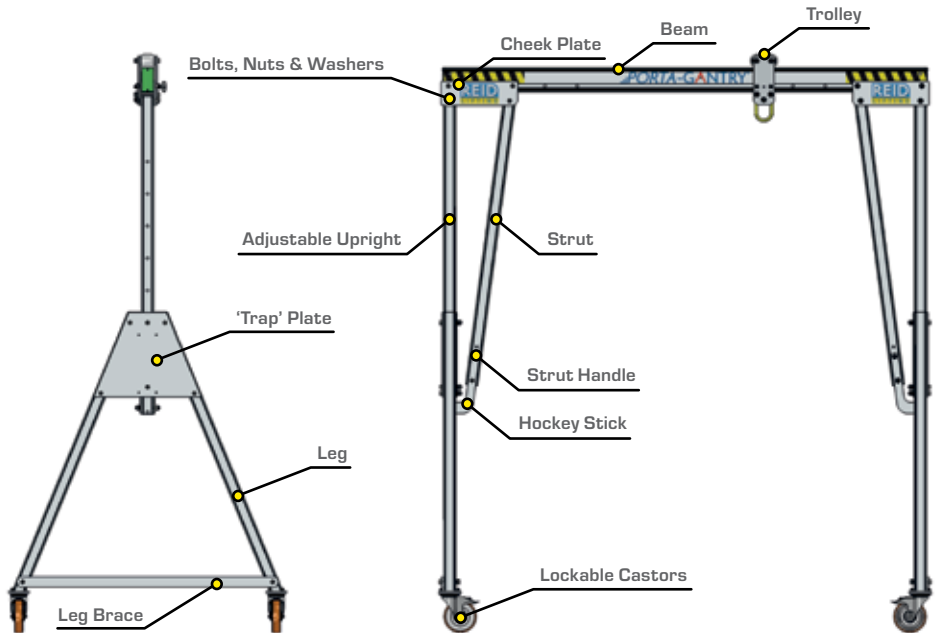

PORTA-GANTRY® 500-3000

No. 1 in lightweight, portable, safe lifting solutions



1. PORTA-GANTRY system delivered flat packed on a pallet:

- 2 x A-Frames
- 1 Trolley
- Beam (sometimes shipped separately)



2. Gantry Tool Set (supplied as an option):

- Ratchet handle 1/2" sq drive
- 24mm socket
- 24mm combination spanner
- 14mm long series allen key
- 14mm Hex key socket



3. A-Frame prior to assembly



4. Assemble each A-Frame by:

- Positioning legs and bolt in place
- Attaching leg brace

The unit is most easily assembled with the A-Frames at their lowest height setting and this is the recommended position to start from.



5. Apply the castor brakes

Put brakes on only with protective footwear ensuring that the castors are in the orientation shown.

Do not use hands



6. Pre Assembly visual check

- Beam
- Trolley
- 2 x A-Frames
- Tool Set (Option)

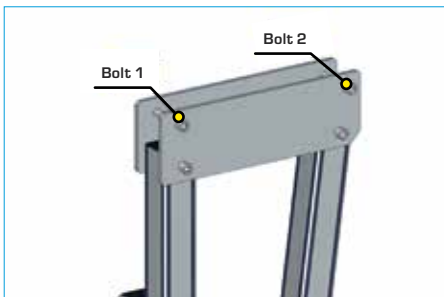

7. Check Plates bolts 1 and 2



8. Lay the two A-Frames a beam length apart on a flat surface in line with each other with the castor wheels outward and brakes on.

Lay the beam on the A-Frames, resting on Bolt 1 on each cheek plate.

..:PORTA-GANTRY® 500-3000

No. 1 in lightweight, portable, safe lifting solutions



9. Offer one end of the beam to the rear bolt-hole on the cheek-plate (Bolt 1) and insert a bolt. Put on plain washer, spring washer then nut, finger tight.



10. Visual Check

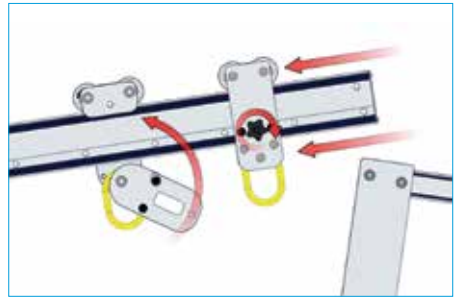

11. Thread beam trolley over the other end of the beam and lock with friction brake at approximately centre position.

Or

Attach gated trolley and lock with friction break.

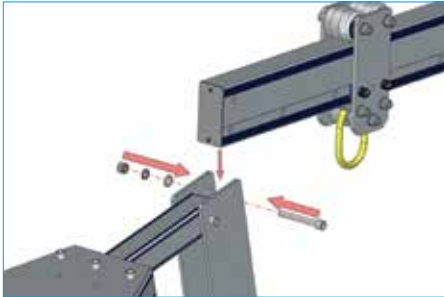

- 12.** Offer opposite side of beam to the rear bolt-hole on the cheek-plate (Bolt 1) and insert bolt. Put on plain washer, spring washer then nut, finger tight.



- 13.** Visual Check



- 14.** At this stage it may be useful to attach the lifting device to the trolley in order to avoid having to lift and attach when gantry is fully erect. This avoids a working at height problem when attaching a hoist.

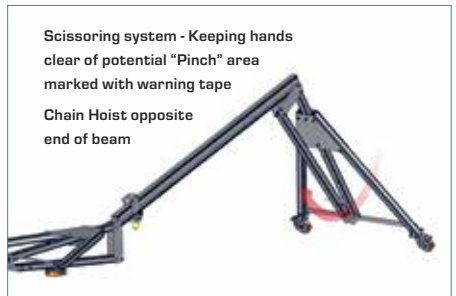

- 15.** With the help of another person, scissor the beam and A-Frame into position (using the first bolt as a hinge).

Be careful not to trap any fingers in this operation

PORTA-GANTRY® 500-3000

No. 1 in lightweight, portable, safe lifting solutions

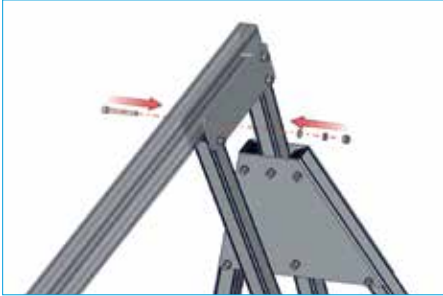

16. Insert the second bolt into the cheek-plate. Tighten both bolts until spring washer is fully depressed. (Do not over tighten)



17. Visual Check



18. Move trolley to other end of beam, opposite to the end to be raised, and secure by tightening the trolley knob.

(For additional safety whilst the beam is at such an angle a spare bolt can temporarily be placed in an adjustment point on the beam to prevent the trolley slipping down the beam)



19. Repeat the scissor activity at the opposite end of the gantry.



20. Insert and tighten the final beam bolt.



21. The gantry is now erect at its lowest height setting.



22. If the hoist is not already attached to the suspension point on the trolley, do so now (using stepladder if height setting requires).

If this is not safe, disassemble the gantry and re-start adding the hoist prior to scissoring the A-Frames.

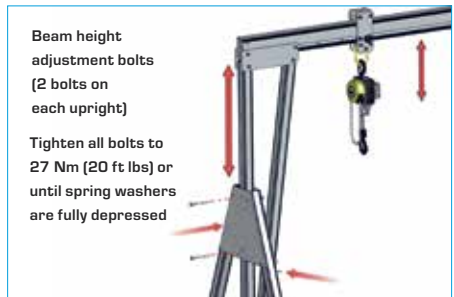

Beam height adjustment bolts (2 bolts on each upright)

Tighten all bolts to 27 Nm (20 ft lbs) or until spring washers are fully depressed

23. Decide on the height required (always using the lowest possible setting for the work in hand). Adjust the upright position on one A-Frame (a 2 man operation – one on the bolts and one on the upright) by removing 2 x upright securing bolts and moving the upright to the appropriate setting by lifting from the strut handle. Re-secure with bolts, nuts and washers (do not over tighten). Repeat the height adjustment at the opposite end.

PORTA-GANTRY® 500-3000

No. 1 in lightweight, portable, safe lifting solutions

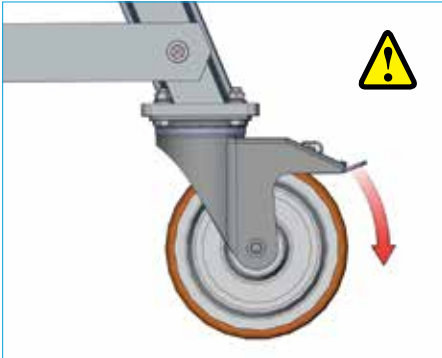

24. Release trolley brake and castor brakes to position the gantry over the load ensuring, when possible, that the load is lifted from the center of the beam.

N.B. ENSURE THE BEAM IS HORIZONTAL AND CASTORS ARE LOCKED PRIOR TO ANY LIFT.

VARIANTS & OPTIONS

- Wind Up Jack Legs
- Ratchet Beam Elevation System
- Easy conversion to winched capability
- Customised Configurations
- PORTA-GANTRY 5000
- PORTA-GANTRY RAPIDE

Wind Up Jack Leg Option (WUJL)

WUJL option may be fitted to the gantry – this gives fine adjustment in the height setting (300mm total lift on the uprights) and gives independent foot adjustment, particularly useful on uneven ground.

NEW 2018

Universal Bracket WLL 500-5000kg capacity.

If the wind up jack legs are fitted the following points must be observed:

1. Check whether the castors fitted are Load Rated (or Pneumatic)

N.B. For pneumatic (non load bearing) castors the WUJL system must always be applied prior to performing any lift. If load rated castors are fitted the operator can choose whether the castors or WUJL take the load on each foot of the gantry.

2. When transporting over ground or manoeuvring the gantry, into position, always have the jack leg in the 'parked' position as in figure 1 right or remove if required
3. Position the gantry for the lift before setting the heights with the jack
4. Before lifting ensure all jacks are in the correct lifting position and are secured with locking pins and clips as in figure 2
5. Manually raise each leg/castor in turn and set the height by rotating jack handle clockwise
6. Having set the adjustment of all four legs, stand back from the gantry and ensure that the gantry uprights are vertical and the beam is horizontal
7. If the ground that the load spreading feet are on is soft and likely to sink when the load is applied put boards under the feet to spread the load further.
8. Having performed the lifting operations, return gantry to it's castors and park the jack leg as in figure 1



Fig.1
Wind Up Jack Leg in 'parked' position



Fig.2
Jacks secured with locking pins and clips



Fig. 3
Example application

7. Re-insert upper bolt and nut/washer assembly
8. Ease tensioned strap aside, and re-insert lower bolt and secure
9. Repeat steps 2-8 on the second A-Frame, ensuring that both A-Frames finish at the same height (or do both in parallel with second person)
10. Check all bolts on the gantry are sufficiently secure by ensuring all spring washers are fully depressed
11. If the hoist is not already attached to the suspension point on the trolley, do so now (using stepladder if height setting requires). If this is not safe, disassemble gantry and re-start from the scissoring operation of the Gantry Assembly Instructions - Step 14

WUJL Inspection/Maintenance

The jack legs and brackets should be subjected to periodic inspections by a competent person in line with gantry inspection and maintenance guidelines (see page 6).

It is recommended that when not in use the jack legs are removed and stored in a clean and dry manner.

The jack leg should be lubricated with EP2 grease on the internal thread and gears, at regular intervals (up to 6 months maximum), depending on service conditions.

Ratchet Beam Elevation System Option

[Two Person Operation Recommended – one on each A-Frame]

Always wear gloves when using this item.

1. Decide on the height required (always use the lowest setting for the work in hand)
2. Ensure the claw-hook at the end of ratchet strap is positively engaged with the bottom hole on A-Frame upright
3. Remove lower bolt on trap plate
4. Tension ratchet strap to take the upright/beam weight
5. Remove upper bolt on trap plate
6. Operate ratchet to adjust height to required setting, ensuring that the bolt holes are aligned



Easy Conversion to Winched Configuration

Beams are ready to accept the sheave carrier and A-Frames are ready to accept any winch brackets.

A winch kit would be required to connect the gantry system for winched use



Read the Winch Kit Assembly & Operation instructions



Winch Kit Assembly & Operation instructions

Customised Configurations

For customised systems additional assembly and operation information may be provided as required.

PORTA-GANTRY® 500-3000

No. 1 in lightweight, portable, safe lifting solutions

PORTA-GANTRY RANGE

Unique portable gantry system that can safely lift up to 5000kg, with manual assembly on just 4 bolts.

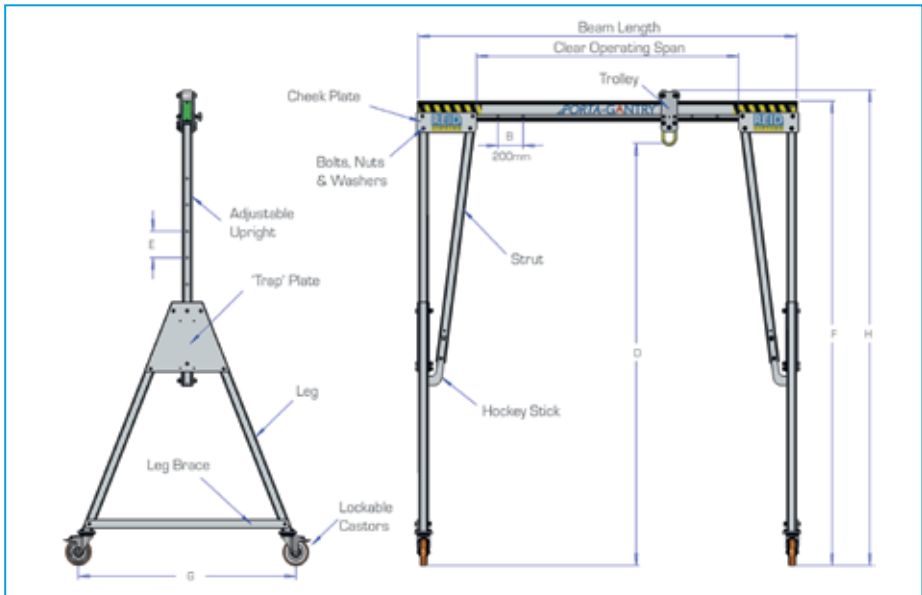

NOTE - Beam Height Adjustment

The height of each gantry beam is easily adjusted by the release of 2 bolts on each upright and can be easily and safely raised into position by increments of 200 or 150mm depending on product.

To assist with this activity a Geared Wheel or Ratchet system is provided for the larger gantries; manual on smaller frames.

PORTA-GANTRY RANGE | Beam Options (mm)

		Standard Beam Length (mm)							
		2500	3000	3920	4570	5500	6000	8400	9000
WLL Rating (kg)	500	19	22	29	34	41	44	62	66
	1000	19	22	29	34	41	44	79	84
	2000	19	22	29	34	52	93	130	X
	3000	19	22	37	43	85	93	130	X
	5000	39	47	61	71	85	X	X	X
		Weight of Beams (kg)							

PORTA-GANTRY RANGE | Detailed Dimensions(mm)

WLL (kg)	Frame size	D _{max}	E	D _{min}	F	H _{max}	H _{min}	G	A-Frame Weight (kg)	Trolley roller size	Castor Diam
		Max height to lifting eye	Height increment	Min height to lifting eye	Max height to top of beam	Max height to top of roller	Min height to top of roller	Width			
500 / 1000	S	2355	5 x 150	1605	2675	2757	2007	1212	33	82	150
	M	2851	5 x 150	2101	3171	3253	2503	1429	40	82	150
	I	3188	5 x 200	2188	3499	3581	2581	1726	46	82	200
	T	4079	6 x 200	2879	4399	4481	3281	2011	51	82	200
	TC4	4527	6 x 200	3327	4847	4930	3730	2234	80	82	200
	TC3	5027	6 x 200	3827	5347	5430	4230	2557	82	82	200
	TC2	5527	8 x 200	3927	5848	5930	4330	2733	87	82	200
	TC1	5829	9 x 200	4029	6149	6231	4431	2733	95	82	200

WLL (kg)	2000	S	2355	5 x 150	1605	2675	2757	2007	1212	38	82	150
		M	2851	5 x 150	2101	3171	3253	2503	1429	40	82	150
		I	3188	5 x 200	2188	3499	3581	2581	1726	46	82	200
		T	4079	6 x 200	2879	4399	4481	3281	2011	51	82	200
		TC4	4527	6 x 200	3327	4847	4930	3730	2234	80	82	200
		TC3	5027	6 x 200	3827	5347	5430	4230	2557	82	82	200
		TC2	5527	8 x 200	3927	5848	5930	4330	2733	87	82	200
		TC1	5829	9 x 200	4029	6149	6231	4431	2733	95	82	200

WLL (kg)	3000	S	2410	5 x 150	1660	2730	2812	2062	1212	55	82	200
		M	2906	5 x 150	2156	3226	3308	2558	1429	60	82	200
		I	3188	5 x 200	2188	3499	3581	2581	1726	70	82	200
		T	4079	6 x 200	2879	4399	4481	3281	2011	82	82	200
		TC4	4527	6 x 200	3327	4847	4930	3730	2234	80	82	200
		TC3	5027	6 x 200	3827	5347	5430	4230	2557	82	82	200
		TC2	5527	8 x 200	3927	5848	5930	4330	2733	87	82	200

WLL (kg)	5000	I	3181	5 x 200	2181	3592	3717	2717	1736	97*	125	200
		T	4049	6 x 200	2849	4487	4612	3412	2021	106*	125	200
		TC4	4500	6 x 200	3300	4938	5062	3862	2234	85	125	200
		TC3	5000	6 x 200	3800	5438	5562	4362	2557	90	125	200
		S & M versions also available as custom systems										
WLL 5000kg dimensions systems are shown using the deeper 'D' section beam												

Dimensions use standard **Master Link Trolley**, other options available to increase resulting height of lift (HoL) and to assist with load movement. | *Weight includes stabiliser legs

..:PORTA-GANTRY® 500-3000

No. 1 in lightweight, portable, safe lifting solutions

PORTA-GANTRY 5000

The PORTA-GANTRY WLL 5000kg is a first in the industry.

Following the design principles of all of the range, the PORTA-GANTRY 5000kg is highly portable, safe and manually operated.



See separate Assembly & Operating manual.



PORTA-GANTRY RAPIDE

Unique, ultra-lightweight, portable, rapid assembly gantry system with goods WLL up to 500kg designed for rapid deployment and operation, confined space/work at height applications, personnel lifting and fall protection up to 3 persons.



See separate Assembly & Operating manual.



QUALITY & SAFETY

ACCREDITATIONS

Quality and safety are key themes throughout this document and the REID Lifting ethos. It is with this in mind that we have undertaken external accreditations to ensure we stay focused on what is important to our clients and users, and ahead of market trends and developments.

REID Lifting is continuously audited by Lloyds Register Quality Assurance (LRQA) (CE body no. 0088) for approval of its Integrated Management System combining quality systems management, environmental issues and the health and safety practices within the company.

- **ISO 9001:2015** - Specifies requirements for a quality management system for any organisation that needs to demonstrate its ability to consistently provide products that meet customer and applicable regulatory requirements and aims to enhance customer satisfaction.
- **ISO 14001:2015** - Specifies the requirements for implementing environmental management systems throughout all areas of the company.
- **OHSAS 18001:2007** - Occupational health and safety management system.
- **LEEA Membership** - REID Lifting is a full member of the Lifting Equipment Engineers Association (LEEA membership 000897). REID Lifting conforms to the main aims of the association which is to achieve the highest standards of quality and integrity in the operations of members. Entry qualifications are demanding and strictly enforced through technical audits based on the Technical Requirements for Members.
- **IRATA** - REID Lifting is an associate member of the Industrial Rope Access Trade Association (IRATA International membership number 148). REID Lifting works in accordance with the IRATA Code of Practice, by doing so, contributes to promote the development of safe systems.



Conformité Européenne (CE)

REID Lifting's products have been designed, tested and approved (as appropriate) by the Conformité Européenne. This certifies that REID Lifting's products meet the demands of the European Directives and Regulations regarding health and safety requirements. The EC type-examination for this device has been carried out by SGS United Kingdom Ltd, 202b, Worle Parkway, Westonsuper-Mare, BS22 6WA, United Kingdom (CE body no.0120) in accordance with Module B of the PPE Regulation. The EC quality assurance system for this device has been carried out by Lloyd's Register Quality Assurance Limited, 1, Trinity Park, Bickenhill Lane, Birmingham B37 7ES, United Kingdom (CE body no. 0088) in accordance with Module D PPE Regulation (EU) 2016/425.

The Queen's Award for Enterprise

REID Lifting has been awarded this prestigious award on four occasions for design, development and sale of lightweight, portable and safe lifting solutions.



- Innovation category 2006 and 2013
- International Trade 2013 and 2018

TESTING

Testing and Technical File review are integral parts of our design and manufacturing process. External verification of products is undertaken where appropriate, using government approved Notified Bodies.

All products have been thoroughly type tested at UKAS accredited laboratories. Each system is supplied with a certificate of conformance and individual record of thorough examination or test.

Full product design and development Technical Files are available for inspection.

PRODUCT IPR

Intellectual property rights apply to all REID Lifting Ltd products. **There are patents in place, or pending, for:**

PORTA-GANTRY | PORTA-GANTRY RAPIDE | PORTA-DAVIT QUANTUM | T-DAVIT

All product names are trade-marks of REID Lifting Ltd:

PORTA-GANTRY | PORTA-GANTRY RAPIDE | PORTA-DAVIT | PORTA-BASE | T-DAVIT | PORTA-GUAD

E&OE

INSPECTION



INSPECTION RECORD



A
B
C
D

* Insert data from serial numbers found on product into table below

Product number(s)* A			
Serial number(s)* B			
WLL* C			
Year of manufacture* D			
Name of user			
Date of purchase			
Date of first use			
Periodic Examination and Repair History			
Date	Inspected by	Pass/Fail	Comments



 +44 (0)1291 620796

 sales@reidlifting.com

 www.reidlifting.com

UK

REID Lifting

Unit 1 Wyview, Newhouse Farm Ind. Estate,
Chepstow, Monmouthshire, NP16 6UD, UK



 +44 (0)1291 620 796
 +44 (0)1291 626 490
 enquiries@reidlifting.com
 www.reidlifting.com

SWEDEN

2LIFT AB

C / O JJ-Group AB
Tryckarevägen 10



434 37 Kungsbacka SWEDEN

 +46 (0)7342 26155
 info.2lift@jjgruppen.se
 www.jjgruppen.se

ITALY

F.A.S. S.p.A.

Via dei Lavoratori 118/120
20092 Cinisello Balsamo ITALY

 +39 (0)2612 4951
 s.scarpetta@fasitaly.com
 www.fasitaly.com

USA & CANADA

Thern, Inc.

5712 Industrial Park Road
PO Box 347, Winona, MN 55987, USA

 +1 507 454 2996
 +1 507 454 5282
 info@thern.com
 www.thern.com

FRANCE

REID Lifting France

P.A. de Kerboulard, Rue Gutenberg
56250 Saint-Nolf FRANCE

 +33 (0)297 53 32 99
 +33 (0)297 53 04 86
 contact@reidlifting.fr
 www.reidlifting.fr

DE & AUT & CH

REID Lifting D-A-CH

Finkenstrasse 26
8280 Kreuzlingen SWITZERLAND

 +41 (0)71 686 90 40
 +41 (0)71 688 51 69
 jesser@reidlifting.de
 www.ecolistec.ch
 www.reidlifting.de

AUSTRALIA

Vector Lifting

43 Spencer Street
Jandakot, WA 6164 AUSTRALIA

 +61 (0)8 9417 9128
 +61 (0)8 9417 4105
 info@vectorlifting.com.au
 www.vectorlifting.com.au



WEBSITE

PGOM500-3000/EN/V20/2018/09

